

191 P/SP

SELF PASTEURIZING COUNTER-TOP SOFT SERVE MODEL



MAIN FEATURES

- Single large cylinder
- Variable overrun setting (40 - 80%, depending on mix)
- Refrigerated holding mode
- Very simple control panel
- High yield beater
- Patented gear mix pump
- Electronic consistency control
- Mix level control
- Direct heating and cooling system
- Small footprint
- Limited ventilation space requirement
- Easy to customize

TECHNICAL DATA

Beater motor

0,9 kW (1,2 Hp)

Approximate weights

Net weight: 143 Kg (315,3 lb)

Gross weight: 168 Kg (370,4 lb)

Air condenser

Clearance: 80 mm (3 in)

Refrigeration system

Compressor: 1,1 kW (1.5 Hp)

Refrigerant: R404A

Max fuse: 10 A

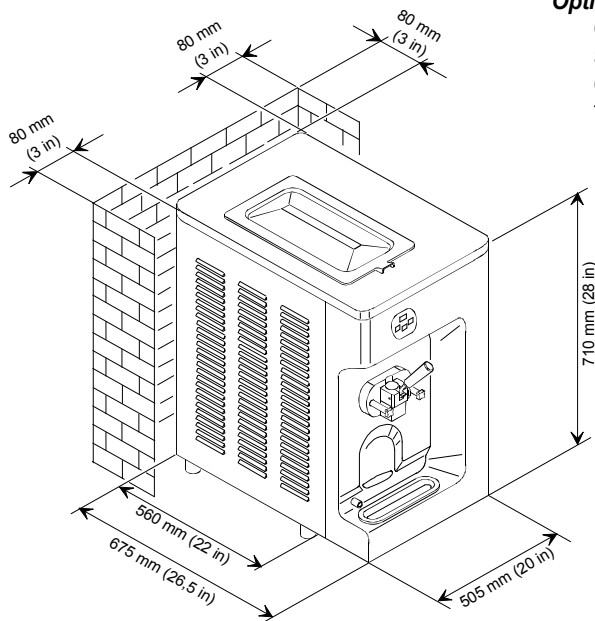

Optionals

- Cone dispenser
- Self serve kit
- Customised front panel
- Two syrup dispenser kit

MODEL	Hourly production * 100 gr (3,5 oz) portions	Hopper capacity liters/qts	Flavors	Electrical supply			Installed power kW/HP	Net weight Kg/lb
				Volt	Phase	Cycle		
191 P/SP	200	12/12,5	1	400	3	50	2,1/2,8	143/315,3

* Hourly production can vary with the mix used and operating conditions.
Data was collected at 25°C ambient temperature.

Due to continuous improvements arising from constant research and development these data are subject to change without notice.



Via Emilia, 45
40011 Anzola Emilia (BO) ITALY
Tel. 051 6505111
Fax 051 732178